

MOUNTING SMALL TAPESTRIES

Today with many artist/weavers producing smaller domestic size tapestries for the wall, presentation of these works has become an important issue. Larger pieces that “hang” well can be suspended from a batten or velcro strip attached to the wall. But those miniature and in-between-sized works that look awkward in a picture frame and cannot hang on their own, what can be done? Developing a presentation specific to each tapestry can be as important as the work itself.

One possible starting place is to address the need to isolate the work from the wall by bringing it forward. Sewing the tapestry to a stretcher frame (similar to those used for stretching canvas in painting) covered in fabric, or a block of plywood or other sturdy material covered in a fabric can accomplish this. Putting a layer of cotton flannel between the fabric and the stretcher allows for an easier sewing space. Sometimes a second larger stretcher again covered with fabric can be added behind the first to isolate the work even further by creating shadows and giving the tapestry another platform to hang from, its own small wall if you like. This allows the small tapestry to fill its own space like a mural tapestry fills its wall, in this way emphasizing the interesting relationship between miniature and mural. Murals because of their size encompass you, miniatures because of their intimate nature pull you into their space and affect the viewer in a similar manner.

In choosing fabric, color and texture can be difficult decisions. Should it compliment, enhance or be strictly neutral? Should it be coarse, textured or smoothly woven? Plain or patterned? How big should the mount be compared to the tapestry, a 1” border vs. a 4” border? Each piece demands a separate evaluation. If desired, work mounted in this way can then be placed in a deep or shallow Plexiglas box which add the element of protection with little or no maintenance, although many prefer the intimacy afforded with nothing between the eye and the work.

Other solutions noted have been pieces mounted on the front of a sheet of plexi, creating only a shadow as a surround, or work sandwiched between two sheets of plexi, allowing examination of both sides of the work; or mounted in a thick 3 dimensional box shaped of frames of wood 10 to 20 times the surface size of the work. Some work has had thin slats of wood added to the sides of the double fabric stretcher mounts. Some have had padded cloth, piping or lace trims added to the edge. All of these methods were successful for the particular tapestry involved but would not have necessarily worked if another tapestry were substituted. In most instances the intent has been to present the tapestry as an object, to enhance its cloth character and to allow it to stand on its own as a woven image.

The personal methods mentioned in most instances have evolved over a period of years and the search for improvement is on going. They are not singular fast solutions because unlike the history of painting and the picture frame, European tapestry has remained primarily a mural art. Small domestic size tapestries for the wall are a more recent 20th and 21st century trend and therefore there is a considerable need to develop its own identity and hence its own history.

The following diagrams illustrate the basic method we use for mounting a small tapestry. This method was originally developed by galleries and museums for display of historical textiles and adapted for contemporary works.

This article originally was written by S. Martin Maffei and originally appeared in a 1997 Tisselise newsletter in Paris, France , subsequently in the TWINE newsletter New England, USA and a further elaboration in Handwoven magazine, May/June 1998.

FLANNEL MOUNT

BACK VIEW

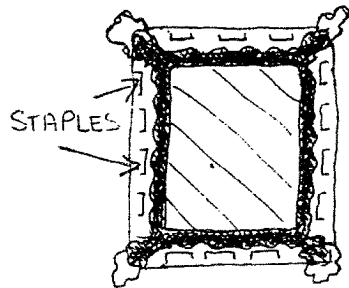
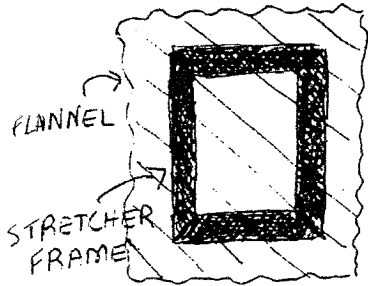

STAPLES
STRETCH & STAPLE FABRIC ON ALL SIDES

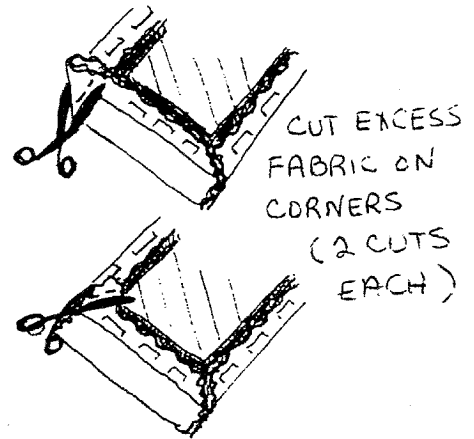

FABRIC MOUNT

BACK VIEW

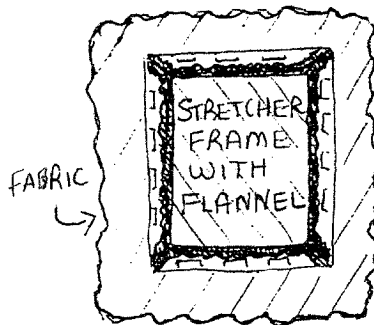

PULL FABRIC TIGHT & HOLD IN PLACE WITH PUSH PINS

STAPLE OPPOSING SIDES

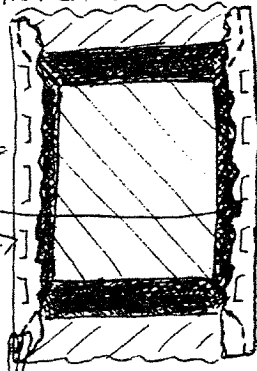

CUT AWAY EXCESS ON CORNERS

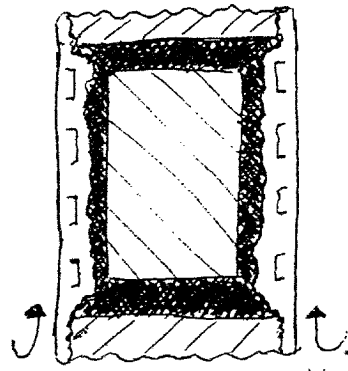

FOLD REMAINING SIDES UP

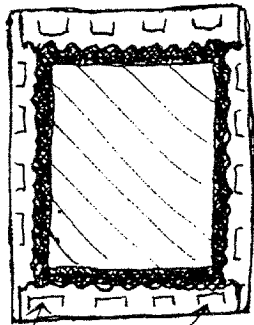

STAPLE

STRETCHER COVERED WITH FLANNEL & FABRIC

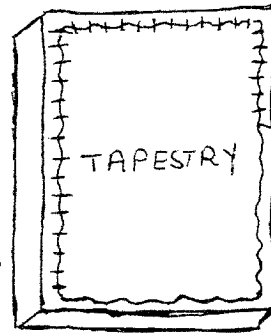

SEW TAPESTRY TO FABRIC

DOUBLE MOUNT

FRONT VIEW

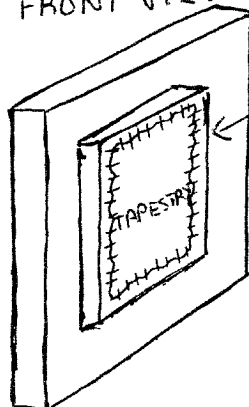

FABRIC COVERED STRETCHERS

BACK VIEW

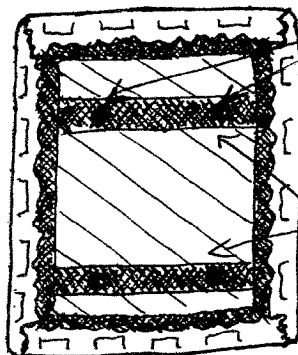

SCREWS ATTACHING 2 STRETCHERS TOGETHER

REINFORCEMENT BARS